

HFH / HFC Series Hydronic Air Handlers
Installation Instructions

AllStyle Coil Company, LP
7037 Brittmore
Houston, TX 77041
Phone 713-466-6333 Fax 713-466-6363

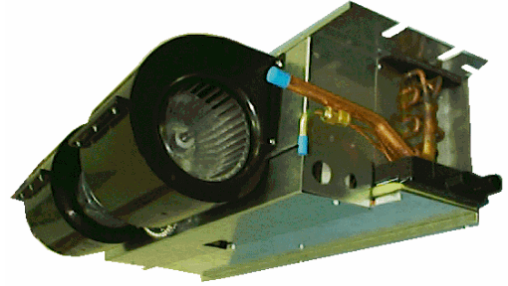

May 2005

**HFH / HFC Series
Hydronic Air Handler**

Installation – Operation – Maintenance

The HFH and HFC series hydronic air handlers are designed for ceiling mount in a recessed area, (furred down) between floors, ceiling/attic area or hung in an acoustic tile ceiling. The HFC series is available in nominal cooling capacities of 1, 1.5, 2, 2.5, and 3 nominal tons of cooling using chilled water. A hydronic coil for heating is included on the HFH model.

Installation Instructions

Installation of this unit shall be made in accordance with the National Electric Code, NFPA No. 90A and 90B, and any other local codes or utilities requirements.

WARNING:

Do not operate this unit unless all service panels/access doors are in place. If unit is located in the same area as the water heater or boiler, then the return air must be ducted to the unit. Seal all service entrances to the unit to prevent combustible byproducts from the water heater or boiler entering the air stream.

WARNING:

Due to possible damage to equipment or personal injury, installation, service and maintenance should be performed by a trained, qualified person. Consumer service is recommended only for filter replacement.

WARNING:

Insure all power is disconnected before installing or servicing this unit. More than one disconnect device may be required to de-energize the equipment. Hazardous voltage can cause sever personal injury. Make certain all panels are in place before operating the unit.

WARNING:

This unit is designed to be connected to a potable water system; therefore, the installation must comply with the applicable code of the local jurisdiction. Regardless of local code requirements, make certain that you do not use ferrous piping in connecting this unit to the water heater. The unit should be installed using new piping that is approved for potable water application.

Do not connect to or use in conjunction with this unit any devices for the purpose of saving energy or increasing operating efficiencies, which have not been tested and approved by AllStyle Coil Company or design certified for use with this unit. Serious damage, reduced unit performance and hazardous conditions including personal injury and property damage may result from the use of devices which have not been approved or certified by AllStyle Coil Co., LP.

HFH / HFC Series Hydronic Air Handlers Installation Instructions

Unpacking

Carefully unpack the unit and inspect the contents for damage. If any damage is found at the time of delivery, proper notification and claims should be made with the carrier who delivered the unit.

Check the rating plate to assure model number and voltage, plus any kits agree with what you ordered. The manufacturer should be notified within 5 days of any discrepancy or parts shortage.

Location

The HFH and HFC series is designed to be installed in a recessed area, (furred down) between floors, ceiling/attic area or hung in an acoustic tile ceiling. Units may be installed in hallways, over bathrooms, or in a commercial drop-in ceiling. These units are designed for indoor use only in a horizontal position

Before attempting installation, the following points must be considered:

- Structural strength of supporting members
- Clearances and provision for servicing
- Power supply and wiring
- Air duct connections
- Drain facilities and connections

Caution

If the unit is located in the same room as the gas water heating appliance, then the return air must be ducted from the conditioned space to the air handler and all doors must be secured in place before operating the system. Make certain that the combustible byproducts of the water heating appliance can not enter the air stream of this system. Contact the local gas inspection department or contact the factory if you have any questions regarding this matter.

Duct Work

The duct work should be installed in accordance with the NFPA No. 90A "Installation of Air Conditioning and Ventilating systems" and No. 90B "Residential Type Warm Air Heating and Air Conditioning Installation."

The duct work should be insulated in accordance with the applicable requirements for the particular type installation as required by HUD, FHA, VA the applicable building code, local utility or other governing body.

Condensate Drain

The unit is supplied with 3/4 inch primary and auxiliary condensate drains. Both drains must be trapped outside the unit and piped in accordance with applicable building codes. Do not reduce the drain line size less the connection size on the drain pan. Condensate should be piped to an open drain or to the outside. All drains must pitch downward away from the unit a minimum of 1/8" per foot of line to ensure proper drainage.

Refrigerant Piping

Refrigerant pipe connections are located on the top of the unit. Refrigerant piping external to the unit shall be sized in accordance with the instructions of the manufacturer of the outdoor equipment. When units are recessed mounted in the wall, make certain that piping connections are pressure tested prior to the wall being closed.

Metering Device

All units are shipped with a checkflow piston installed which is designed for air conditioning or heat pump operation. If your application requires a thermal expansion valve or check expansion valve then it is necessary to remove the piston from the distributor assembly and install the proper metering device. Be sure to follow the instruction in the kit to ensure proper installation.

Blower

This unit is supplied with a multi-speed motor with a direct drive blower wheel which can obtain various air flows. The unit is shipped with the blower connected for high speed. If a lower blower speed is required, disconnect all power to the unit, remove the black indoor fan motor lead from the fan relay, place an insulated cap on the black lead, remove the insulated cap from the red indoor fan motor lead, place a spade connector on the lead and connect it to the fan relay where the black lead was originally connected. Be sure to check the air flow and the temperature drop across the evaporator coil to ensure that you have sufficient air flow.

Wiring

Consult all schematic and pictorial wiring diagrams of this unit and the outdoor equipment to determine compatibility of the wiring connections and to determine specific requirements.

HFH / HFC Series Hydronic Air Handlers

Installation Instructions

All field wiring to the blower coil should be installed in accordance with the latest edition of the National Electric Code NFPA No. 70 and any local codes.

Check rating plates on unit for rated volts, minimum circuit ampacity and maximum over current protection. Supply circuit power wiring must be 75 degree C. (167 degree F) minimum copper conductors only. Copper supply wires shall be sized to the National Electric Code or local code requirements, whichever is more stringent. The unit is shipped wired for 115/120 Volt AC 60 HZ 1 Phase Operation.

Be sure the unit is properly grounded.

Class 2 low voltage control wiring should not be run in conduit with power wiring and must be separated from power wiring, unless class 1 wire of proper voltage rating is used. Low voltage control wiring should be 18 Awg, color coded (105 degree C minimum). For lengths longer than 100ft., 16 Awg wire should be used. Make certain that separation of control wiring and power wiring has been maintained.

Make sure that separation of control wiring and power wiring has been maintained.

Air Filter

An air filter must be installed prior to the air entering the evaporator coil to protect the coil, blower and other internal parts from excessive dirt and dust. The door must be securely fastened in place to ensure proper filtration of the return air. A remote return air filter grille may be used for ducted return applications. Change the filter every 30 days or as soon as dust or dirt appears on the filter. Failure to change the filter in a timely fashion can result in reduced airflow, increased operating cost and may result in damage to the unit and or outdoor unit.

Thermostat

Select a thermostat that is commonly referred to as a single stage cooling with electric heat subbase. This stat will energize the fan on a demand for heat or cool.

Install the thermostat on an inside wall, away from drafts, lights or other heat sources in a location that has good air circulation from the other rooms being controlled by the thermostat. The thermostat should be mounted 4 to 5 feet above the floor.

Refer to the wiring diagram in the back of this manual for complete wiring instructions

Water Piping

This unit requires hot water that is supplied from an external source. Piping is required to connect the water source and this air handling unit. This piping must be installed in accordance with prevailing building, safety and N.E.C. codes and requirements.

1. Material: It is recommended that all piping between the water heater and the hot water coil be 3/4" nominal (7/8 OD) copper or "polybutylene". Other material approved for potable hot water systems may also be used if approved by local code authorities. Use only brass or copper fittings on joints.....NEVER USE plastic fittings.

2. Solder Connections: ALL copper joints in the water lines must be made with low temperature, non-lead solder.

3. Insulation: It is recommended that all piping be adequately insulated to prevent freezing and a "Low Limit Control: (See "Options") be installed on the hot water coil to prevent freezing when piping is run in a space subject to freezing conditions.

4. Length: Piping should not exceed 140 total feet in length

5. Shut-off Valves: In addition to the main cold water valve supplying the water heater, it is recommended that on shut-off valve be installed on the hot water supply line to the air handler and one on the return line from the air handler (or hot water coil). These valves will facilitate air purging during start-up and allow unit isolation for repair.

6. Piping connections: The water inlet or "supply" connection to the hot water coil is marked accordingly. Air handlers with internally installed circulating pumps will not heat if piped backwards. Water lines to and from the air handler must be connected to the horizontal connection of the "T" fittings in the vertical hot and cold water supply lines at the water heater. This insure that any air in the water heater will bypass the heating loop and then be purged each time hot water is used in the dwelling. If this piping procedure is not followed the pump may "air lock" and fail to pump hot water. If it is necessary to "T" off from a horizontal hot water line, we recommend coming off the bottom of the horizontal line to feed the air handler or hot water coil. Any other piping procedure must address the elimination of air in the heating loop. Contact the factory for assistance with alternate piping procedures.

HFH / HFC Series Hydronic Air Handlers Installation Instructions

Air handler: Holes should not be drilled into the air handler or coil cabinets (except through duct flanges) since damage to the coils could result. Multiple air handler may be installed on one water heater provided the water heater is sized properly. Piping should be similar to that required for individual air handler.

Water heater: Water heaters should be installed according to the manufacturer's installation instructions. If a "back flow preventer" is required by code, the T & P valve on the water heater may tend to drip water because of pressure build-up in the water heater. This problem is a direct result of the back flow preventer..... not the heating system. An expansion tank may need to be installed to solve this problem. Most water heaters are now labeled with this information.

Multiple water heaters: When sizing requirements call for more than one water heater per air handler, water heaters may be connected together according to the water heater manufacturer's instructions.

Mixing valve: A water heater is designed to produce hot water. Hot water represents a serious safety hazard due to the potential of scalding. The temperature of water normally required to provide space heating (120 to 140 degrees) may be, hotter than. Certain codes allow for domestic hot water. A "mixing valve" can be installed in the hot water piping which would allow a lower temperature than the space heating water. These can be obtained locally and should be installed according to the manufacturer's installation instructions.

This system may be used in conjunction with potable water or closed loop systems. It is strongly recommended that a licensed contractor be employed to install the required water piping.

This unit maybe operated with water temperatures reaching 180 degrees. The use of a water tempering valve is recommended on systems which tie to potable water systems.

Use only new materials when installing this unit. Suitable types of material are copper polybutylene rated for hot water of the temperature you are utilizing. Other materials approved for potable hot water applications may also be used if approved by local code authorities.

START UP (Cooling Mode)

Once all connections are completed, the unit should be started up and a check out of the completed system should be performed. Before performing any system test make sure that all grilles, register and dampers are

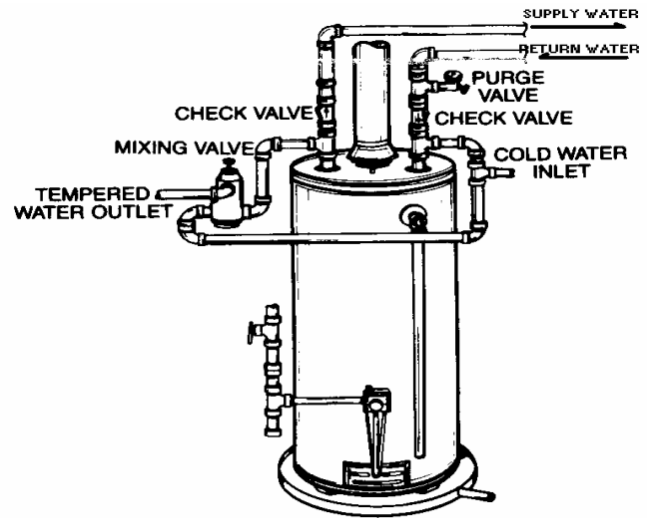

open and set to the correct position. Also make certain that an air filter is installed in the return air prior to the Air Handler.

A performance test should be completed in accordance with the outdoor equipment manufacturer's instructions. Airflow tests should be conducted in the heating and cooling modes to ensure satisfactory operation.

START UP (Heating cycle)

1. Open the main shut - off valve to the water heater and the two shut - off valves to and from the air handler or hot water coil.
2. Fill the water heater. Open a hot water faucet somewhere in the house while filling the water heater in order to vent the air. When the tank is full and all the air is purged, close the faucet.
3. Ignite the water heater according to the manufacturer's instructions and allow it to come up to temperature (about 45 minutes). **DO NOT IGNITE THE WATER HEATER WITHOUT WATER IN THE TANK!**
4. Purge the air handler hot water coil and lines. Once the air is completely removed upon start - up, the circulating pump will circulate the required amount of hot water through the heating loop providing the pipe has been properly sized.
5. On Grundfos pumps, vent the air from the pump chamber by loosening the large screw plug on top of the

HFH / HFC Series Hydronic Air Handlers Installation Instructions

pump motor until water appears. Then, re-tighten the plug.

6. Switch the room thermostat to "heat" and set it high enough to energize the fan motor and pump. It may be necessary to "feel" the pump to determine it is operating. If the pump is operating properly and the water temperature in the water heater has reached the set point, the hot water line going into the air handler will begin to get hot. The return line from the VLW should be 15 to 20 degrees cooler than the supply line. If the pump is running but hot water is not circulating, refer to "troubleshooting".

7. Adjust the water heater thermostat so that the water entering the hot water coil is 135 to 140 degrees with the system energized and operating long enough for all temperatures to stabilize.

IMPORTANT: For system to operate properly power should be turned ON and all shut - off valves should be OPEN.

TROUBLE SHOOTING: (Heating Mode)

Pump does not run: These pumps may sometimes "stick" due to non - use and fail to start. Before replacing Pump:

1. Turn off power. On Grundfos pumps remove large screw plug in end of pump motor and turn shaft several times with a small screwdriver. Replace plug and start system. Pump should start.

2. If pump has to be replaced, first disconnect electrical power to the unit, disconnect electrical power supply to the pump, shut off all isolation valves between the water heater and air handler and relieve the city water pressure by opening the air purge valve. Then remove the four screws that attach the pump motor to the pump volute rather than unsoldering the entire pump assembly. Fan motor runs on cooling but not on heating: (Units equipped with optional EWT) Check the temperature of the water leaving the pump, it must be a minimum of 120 degrees for the entering water thermostat to close and allow the fan to run. If the water temperature is above 120 degree, (CAUTION: THE EWT IS WIRED TO HIGH VOLTAGE) then check the EWT by ohming the leads to insure that it is closed. If the switch is open and the water temperature is above 120 degrees, then replace the EWT.

If the EWT checks good, then ascertain whether you have the correct control Thermostat installed. If the thermostat is the wrong type (a gas furnace type

thermostat will not bring on the fan motor in the heating cycle on certain air handlers). For correct type of thermostat, see "System Components".

Pump is noisy: Air may still be in the heating loop. Re-purge the system as described under "start - up procedure".

Sequence of Operation

Cooling When the thermostat calls for cooling, the circuit between R and G is completed, and the blower relay is energized. The N.O. contacts will close and the indoor blower will operate. The circuit between R and Y is completed: causing the contactor on the outdoor equipment to close and start the compressor and the outdoor fan motor.

Once the temperature of the air passing over the thermostat reaches the set point, the thermostat will de-energize the circuit between R and Y and cause the contactor on the outdoor unit to de-energize. At the same time the circuit between R and G is interrupted and the indoor fan will stop.

Heating When the thermostat calls for heat, the circuit between R and W is completed, the pump relay is energized and causes the circulation pump to start. Hot water is circulated through the hydronic coil. The fan relay is energized and the indoor fan comes on. This forces the air from the structure through the hydronic coil and heat is rejected from the water coil to air which is then distributed through the duct work of the structure. When the thermostat is satisfied, the pump relay and the fan relay will be de-energized and the pump and fan will be shut off.

Maintenance

The system air filter(s) should be inspected, cleaned or replaced at least monthly. If the filter is mounted internal to unit, make sure that electrical power is disconnected before removing the access panels. Make certain that the access panels are replaced and secured properly before placing the unit back in operation. This product is designed for dependable service; however, periodic maintenance should be scheduled to be conducted by trained professional service personnel. This service should be conducted at least annually, and should include testing and inspection of electrical and refrigerant components. The heat transfer surface should be cleaned. The blower motor is permanently lubricated for normal operating conditions.

HFW / HFC Series Hydronic Air Handlers
Installation Instructions

Warnings

Do not store or use any corrosives or combustibles in the vicinity of this unit. All panels must be in place and properly secured before operating this equipment.

All electrical power servicing this unit must be disconnected prior to removal of any panels. Service of this unit must be accomplished by qualified trained professional personnel only

Conforms to UL STD 1995

THIS UNIT IS MANUFACTURED IN THE USA BY:

AllStyle Coil Co., LP
7037 Brittmore
Houston, TX 77041



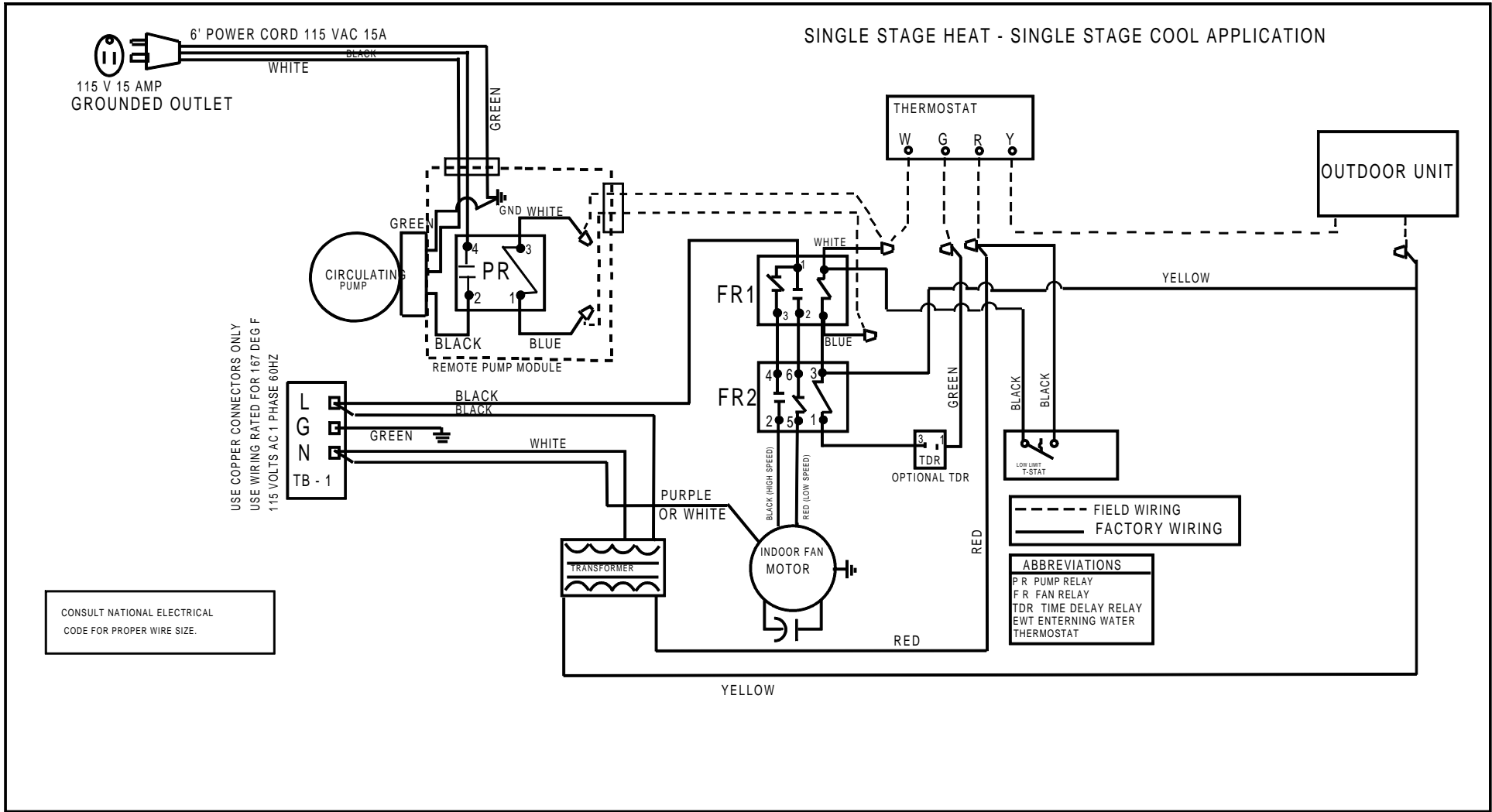

115 VOLTS AC 1 PHASE 60HZ

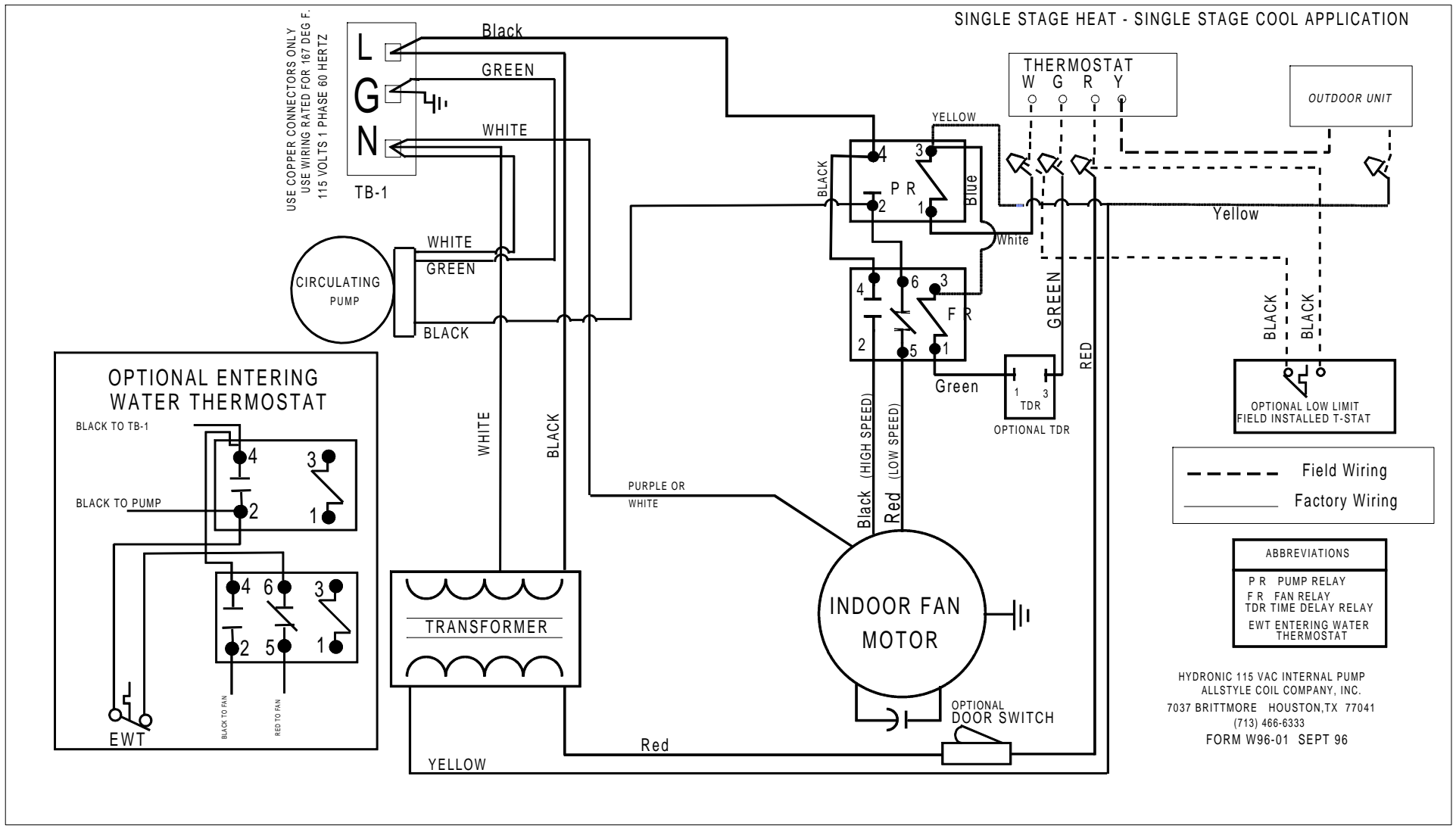

115 VOLTS AC 60 HZ SINGLE PHASE