

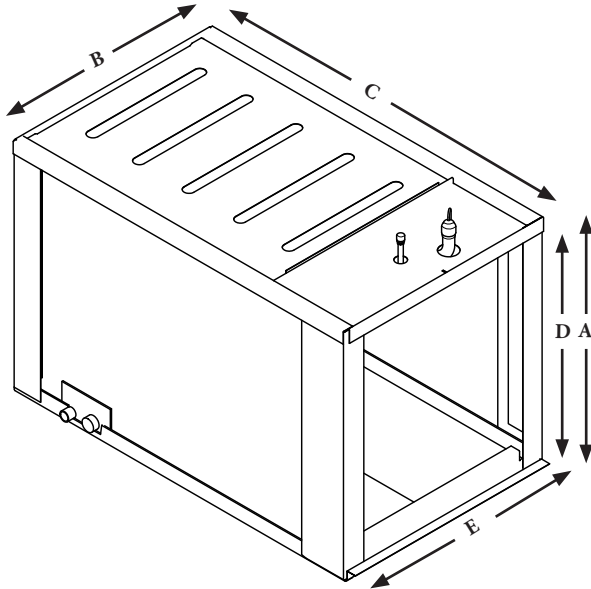

ASLT, ASLB, ASFM, ASKM ALL - IN - ONE PLENUM COILS



3/4" FPT Primary Drain Connection
3/4" Slip Secondary Drain Connection
3/8" Refrigerant Liquid Line
Refrigerant Suction Line
1.5 to 3.0 Tons - 3/4"
3.5 to 5.0 Tons - 7/8"
Optional Galvanized Steel Cabinet

Cabinet Specifications					
Model	Height A	Width B	Length C	Opening D	Opening E
ASLT	18.25"	20.25"	26.25"	13.00" to 18.00"	16.00" to 20.25"
ASLB	18.25"	20.25"	34.375"	13.00" to 18.00"	16.00" to 20.25"
ASLL	18.25"	20.25"	40.375"	13.00" to 18.00"	16.00" to 20.25"
ASFM	22.25"	20.25"	34.375"	17.00" to 21.00"	16.00" to 20.25"
ASFL	22.25"	20.25"	40.375"	17.00" to 21.00"	16.00" to 20.25"
ASKM	26.25"	20.25"	34.375"	21.00" to 23.00"	16.00" to 20.25"
ASKL	26.25"	20.25"	40.375"	21.00" to 23.00"	16.00" to 20.25"
Specifications may change without notice					



Used in place of Metal Drain Pan.
Screws onto cabinet.

- Sturdy Safety Auxiliary Drain Pan Exact Fit for AllStyle Plenum Coils
- Seamless One Piece 3/4" FPT Drain Connection
- Mounting Brackets are Integral to the Drain Pan

HORIZONTAL PLENUM BLOWER HOUSING

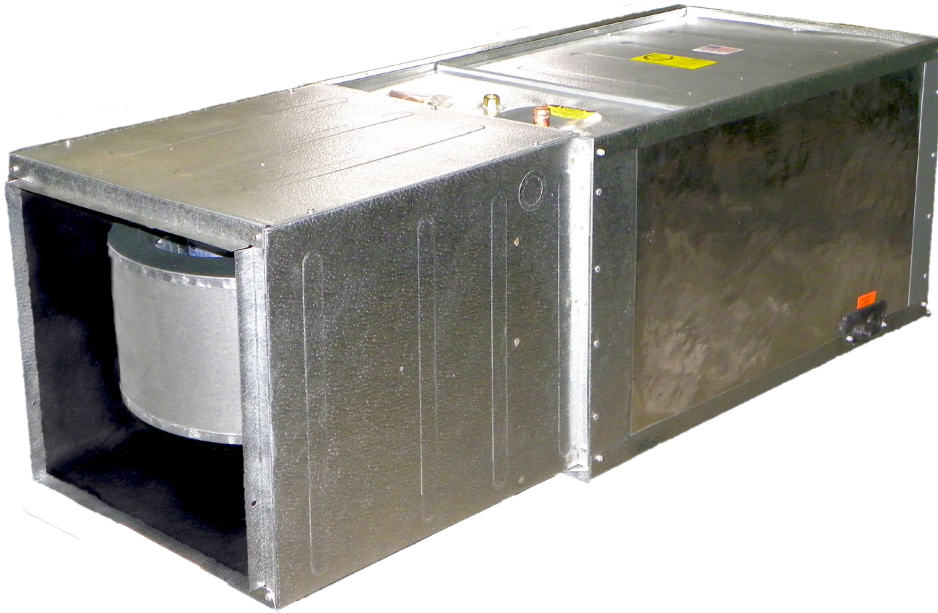

- Plenum Coils may be installed with an AllStyle blower housing or with a gas furnace
- Optional electric heat (3kW, 6kW, 8kW, or 10kW)
- Blower Housing has optional ECM motors
- Optional Embossed Galvanized Steel or Painted Cabinet

Blower Housing Dimensions			
Blower Housing	Blower Housing Height	Blower Housing Width	Blower Housing Depth
EPL 2 - 3 Ton	17.00"	17.00"	20.75"
EPM 4 Ton	19.00"	19.00"	24.00"
EPM 5 Ton	19.00"	19.00"	24.00"
EPK 5 Ton	19.00"	19.00"	24.00"

