

GENERAL

The SL / BL* Series is designed for installation in a closet, utility room, alcove, basement, crawlspace or attic. These versatile units are applicable to flowrator, expansion valve, or check and expansion valve DX air conditioning, and heat pump applications. Several models are available to meet the specific requirements of the outdoor equipment. Factory installed electric resistance heaters are available.

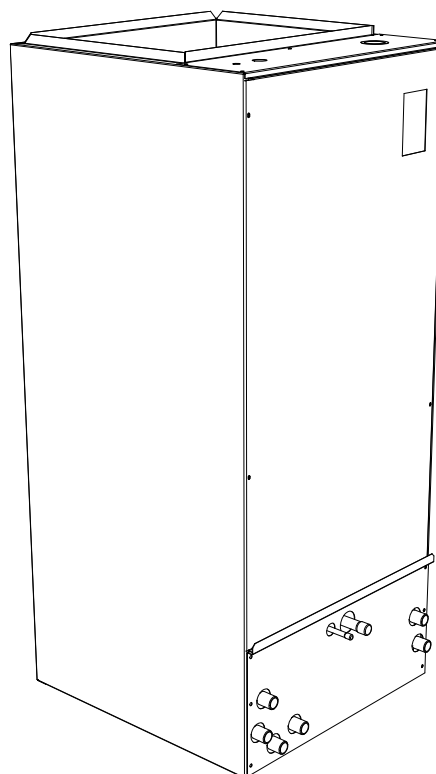

! WARNING: Due to possible damage to equipment or personal injury, installation, service and maintenance should only be performed by a trained, qualified person. Consumer service is recommended only for filter replacement.

Installation of this unit shall be made in accordance with the National Electric Code, NFPA No. 90A and 90B, and any other local codes or utilities requirements.

! WARNING: HAZARDOUS VOLTAGE - Ensure all power is disconnected before installing or servicing this unit. More than one disconnect device may be required to de-energize the equipment. Hazardous voltage can cause severe personal injury. Make certain all panels are in place before operating this unit.

IMPORTANT:

It is not necessary to remove the coil during installation. The SL / BL* Series units may be installed in the vertical up-flow position or either the left or right hand horizontal position.

THE SL / BL* SERIES UNITS DO NOT REQUIRE REPOSITIONING OF DRAIN PANS. UNITS ARE SHIPPED WITH HORIZONTAL LEFT, HORIZONTAL RIGHT, AND UP-FLOW PANS INSTALLED.

INSTALLATION GUIDE

UNPACKING

Carefully unpack the unit and inspect the contents for damage. If any damage is found at the time of delivery, proper notification and claims should be made with the carrier who delivered the unit.

Check the unit rating plate to ensure model number and voltage, plus any kits agree with what you ordered. The supplier should be notified immediately of any discrepancy or parts shortage.

LOCATION

The blower coil unit should be centrally located. The unit may be installed in an attic, basement or crawl space with 0" clearance from any side, front, rear or duct work.

NOTE: If the unit is located above a finished ceiling or living space, an auxiliary safety drain pan must be installed under the unit. A separate drain line must be installed from the safety pan.

The unit must be installed in a level position to ensure proper condensate drainage. Make certain the unit is level in both directions within 1/8".

When the unit is installed in an enclosed area, the room should be large enough, and have an opening large enough to allow replacement of the unit. All servicing is done from the front. A clearance of 24" is needed for service, unless the closet door aligns with the front of the unit.

NOTE: If you are installing the unit in an unconditioned space such as an attic or crawlspace, you must ensure that the area provides sufficient air circulation to prevent moisture collection on the cabinet during high dew point conditions. A drain pan must be installed under the entire unit when it is installed above a finished ceiling or location in an unconditioned space.

DUCT WORK

The duct work should be installed in accordance with the NFPA No. 90A "Installation of Air Conditioning and Ventilating Systems" and NFPA No. 90B "Residential Type Warm Air Heating and Air Conditioning Installation".

The duct work should be insulated in accordance with the applicable requirements for the particular type installation as required by HUD, FHA, VA, the applicable building code, local utility, or other governing body.

CONDENSATE DRAIN

The unit is supplied with 3/4" primary and auxiliary condensate drains. Both drains must be trapped outside the unit and piped in accordance with applicable building codes. Do not reduce the drain line size less than the connection size on the drain pan. Condensate should be piped to an open drain or to the outside. All drains must pitch downward away from the unit a minimum of 1/8" per foot of line to ensure proper drainage.

REFRIGERANT PIPING

Refrigerant piping external to the unit shall be sized in accordance with the instructions of the manufacturer of the outdoor equipment.

METERING DEVICE

All units are shipped with a checkflow piston or thermal expansion valve installed, which is designed for air conditioning or heat pump operation. If your application requires a thermal expansion valve or check expansion valve and the unit is ordered with a piston, then it is necessary to remove the piston from the distributor assembly and install the proper metering device. Be sure to follow the instruction in the kit to ensure proper installation.

BLOWER

This unit is supplied with a multi-speed motor with a direct drive blower wheel which can obtain various air flows. As an option, ECM X-13 motor is available. This motor provides variable speeds, at a constant torque, with a brush-less DC motor. The unit is shipped with the blower connected for high speed. If a lower blower speed is required. Disconnect all power to the unit, remove the black indoor fan motor lead from the fan relay, place an insulated cap on the black lead, remove the insulated cap from the red indoor fan motor lead, place a spade connector on the lead, and connect it to the fan relay where the black lead was originally connected. Be sure to check the air flow and the temperature drop across the evaporator coil to ensure that you have sufficient air flow.

WIRING

Consult all schematic and pictorial wiring diagrams of this unit and the outdoor equipment to determine

INSTALLATION GUIDE

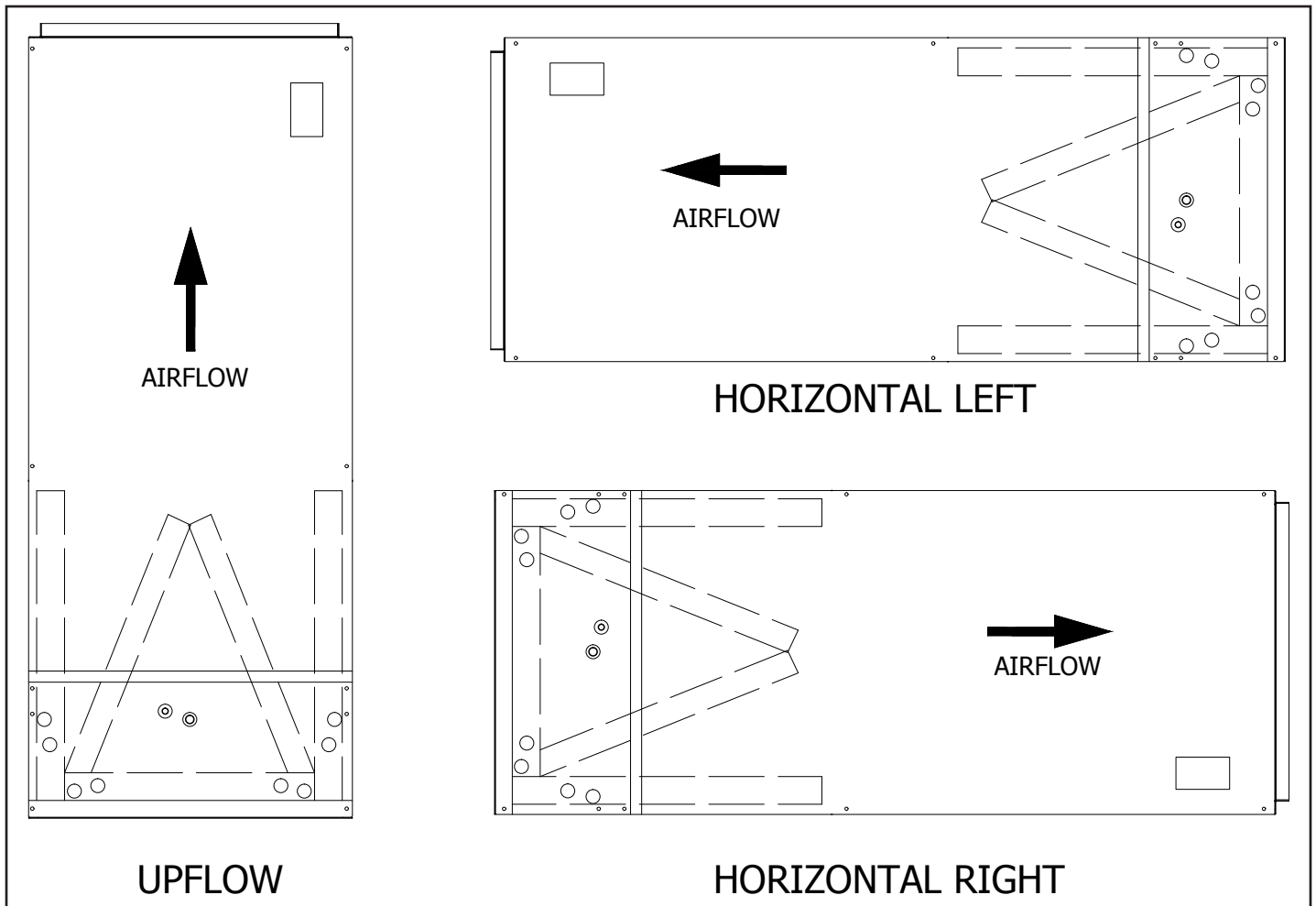

Figure 1. Typical Installation

compatibility of the wiring connections and to determine specific requirements. All field wiring to the blower coil should be installed in accordance with the latest edition of the National Electric Code NFPA No. 70 and any local codes.

Check rating plates on unit for rated volts, minimum circuit ampacity, and maximum over current protection. Supply circuit power wiring must be 75°C (167°F) minimum copper conductors only. Copper supply wires shall be sized to the National Electric Code or local code requirements, whichever is more stringent.

The unit is shipped wired for 230/240 VAC, 60 Hz, 1 Phase Operation. If the unit is to be operated at 208 VAC/ 60 Hz, then follow the instructions on the indoor unit wiring diagram to change the low voltage transformer to 208 VAC operation.

Be sure the unit is properly grounded.

Class 2 low voltage control wiring should not be run in conduit with power wiring. The unit must be separated from power wiring, unless Class 1 wire of proper voltage rating is used. Low voltage control wiring should be 18 Awg, color coded (105°C minimum). For lengths longer than 100ft., 16 Awg wire should be used. Make certain that separation of control wiring and power wiring has been maintained.

AIR FILTER

An air filter must be installed prior to the air entering the evaporator coil to protect the coil, blower, and other internal parts from excessive dirt and dust. If the unit is installed for the return air through the unit base, then the internal filter rack may be utilized.

If you decide to use a remote filter, then it should be sized for a maximum of 300 feet/minute air velocity.

INSTALLATION GUIDE

Change the filter every 30 days or as soon as dust or dirt appear on the filter. Failure to change the filter in a timely fashion can result in reduced air flow, increased operating cost, and may result in damage to the indoor unit and/or outdoor unit.

THERMOSTAT

Select a thermostat that is commonly referred to as a single stage cooling with electric heat sub base. This thermostat will energize the fan on a demand for heat or cool.

Install the thermostat on an inside wall, away from drafts, lights, or other heat sources in a location that has good air circulation from the other rooms being controlled by the thermostat. The thermostat should be mounted 4 to 5 feet above the floor.

START UP

Once all connections are completed, the unit should be started up, and a check of the completed system should be performed. Before performing any system test make sure that all grilles, registers, and dampers are open and set to the correct positions. Also make certain that an air filter is installed in the return air prior to the Air Handler. A performance test should be completed in accordance with the outdoor equipment manufacturer's instructions. Airflow test should be conducted in the heating and cooling modes to ensure satisfactory operation.

SEQUENCE OF OPERATION

Cooling. (Cooling only or heat pump with reversing valve energized in heat mode). When the thermostat calls for cooling, the blower relay is energized. The N.O. contacts will close, after a time delay, and the indoor blower will operate. The circuit between R and Y is complete. Which allows the contactor on the outdoor equipment to close, start the compressor and the outdoor fan motor.

Cooling. (Heat pump with reversing valve energized in cooling mode). When the thermostat calls for cooling, the circuit between R and G, and R and O is complete. Circuit R and O energizes the reversing valve to the cooling position. Circuit R and O energizes the blower relay. The N.O. contacts will close, after a time delay, and the indoor blower will operate. The circuit between R and Y is complete, which allows the contactor on the outdoor equipment to close, and start the compressor and outdoor fan motor.

Heating. (Electric heat only). When the thermostat calls for heat, the circuit between R and W is complete, and the heat sequencer is energized. A time delay will occur, allowing the heating element(s) and the indoor blower motor to come on.

Heating. (Heat pump reversing valve energized in heat mode). When the thermostat calls for heat, the circuits between R and B, R and Y, and R and G are complete. Circuit R and B energize the reversing valve, switching it to the heat position. Circuit R and Y energized the outdoor unit contactor, starting the compressor and outdoor fan. Circuit R and G energizes the blower relay, starting the blower motor.

If the indoor room temperature should continue to fall, circuit R and W2 is by the second-stage heat bulb on the thermostat. Circuit R-W2 energizes the heat sequencer. The completed circuit will energize the supplemental electric heat.

Blower Time Delay. This unit is equipped with timed on and a timed off relay. This relay delays the start and delays the stopping of the indoor fan motor to maximize the efficiency of the unit.

Defrost. When the unit starts the defrost cycle, supplemental heat during defrost can be provided by connecting B on the blower coil to the defrost relay on the outdoor heat pump. This will complete the circuit between R and B in the blower coil, through a set of contacts in the defrost relay in the outdoor unit. This circuit, when it is connected, will help prevent cold air from being discharged from the indoor unit during the defrost mode.

MAINTENANCE

The system air filter(s) should be inspected, cleaned, or replaced at least monthly. If the filter is mounted internal to the unit, make sure that electrical power is disconnected before removing the access panels. Make certain that the access panels are replaced and secured properly before placing the unit back in operation. This product is designed for dependable service however, periodic maintenance should be scheduled to be conducted by a trained professional service personnel. This unit service should be conducted at least annually, and should include testing, inspection of electrical and refrigerant components. The heat transfer surface should be cleaned. The blower motor is permanently lubricated for normal operating conditions.

INSTALLATION GUIDE



Do not store or use any corrosives or combustibles in the vicinity of this unit. All panels must be in place and properly secured before operating this equipment.

All electrical power servicing this unit must be disconnected prior to removal of any panels. Service of this unit must be accomplished by qualified trained professional personnel only.

THIS UNIT IS MANUFACTURED IN THE USA



Intertek



Conforms to UL STD 1995

WIRING DIAGRAM

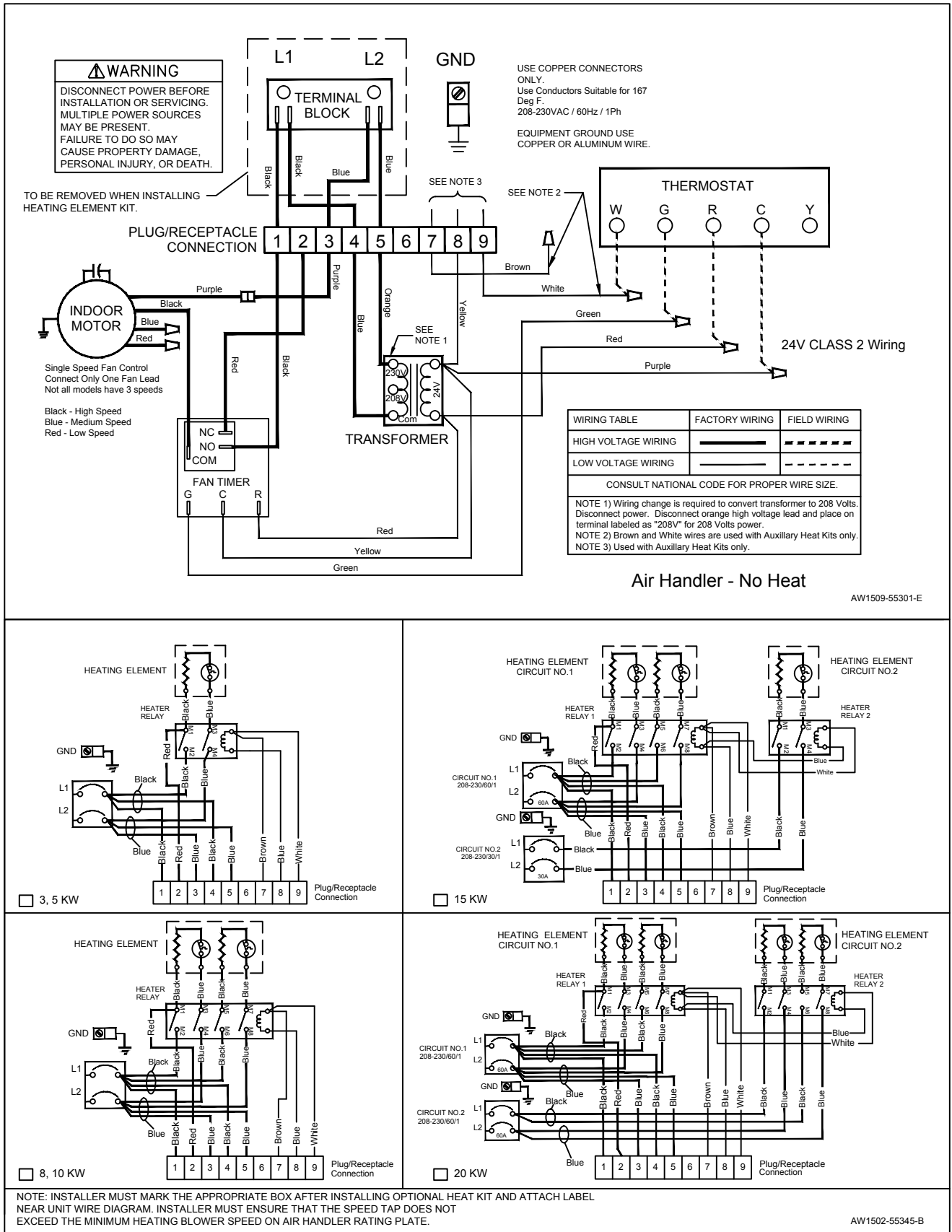

WIRING DIAGRAM

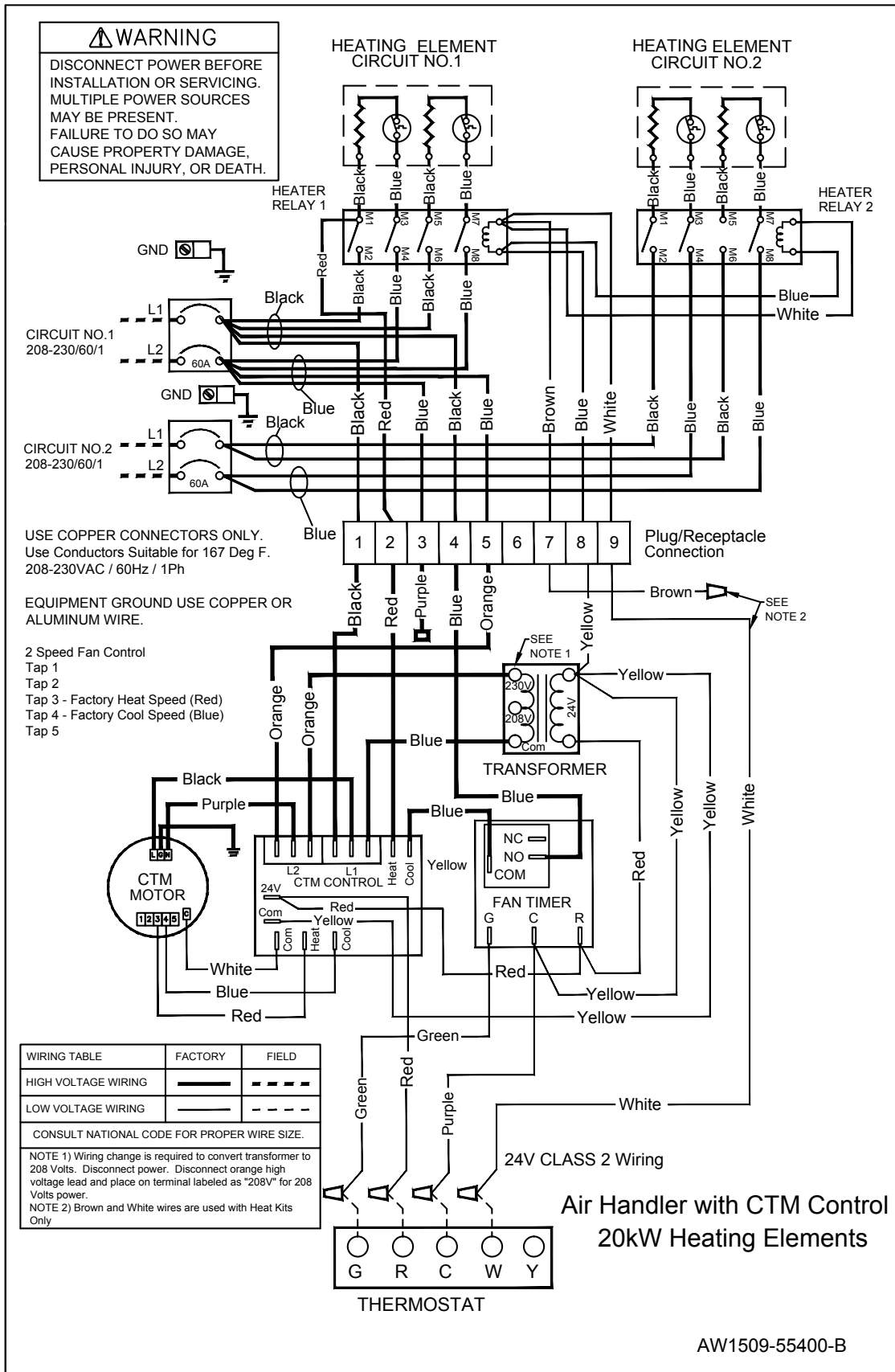

WIRING DIAGRAM

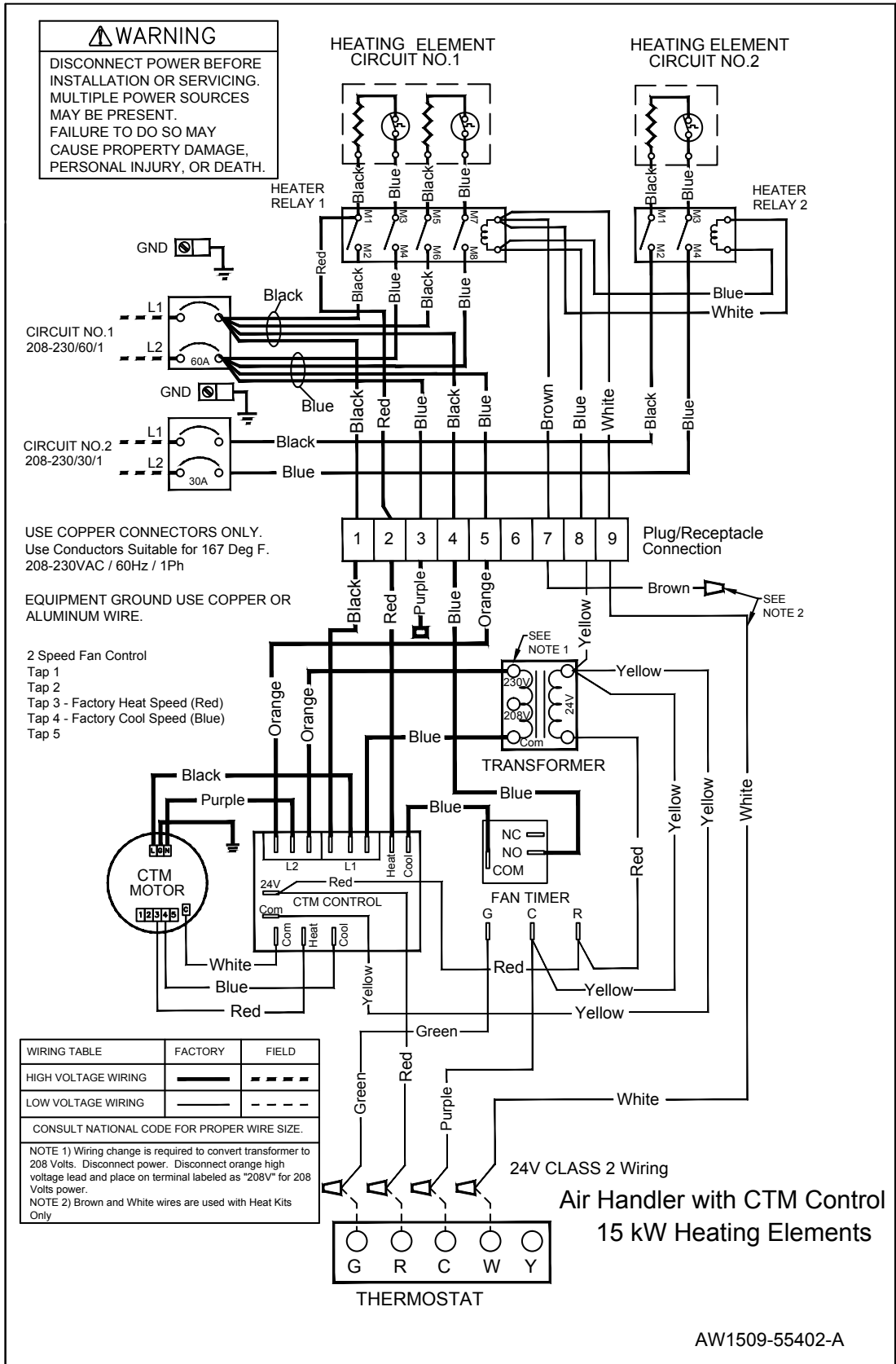

AW1509-55402-A