



# ATCH SERIES REPLACEMENT COILS

## STANDARD FEATURES

**FACTORY INSTALLED THERMAL EXPANSION VALVE**  
**EMBOSSED GALVANIZED STEEL CASE**  
**HEAVY RIFLED COPPER TUBING**  
**ALUMINUM FINNS**  
**ALUMINUM END PLATES**  
**PRESSURE TESTED TO 450 LBS.**  
**DUAL RATED FOR R-22 AND R-410a**  
**STANDARD POLYMER DRAIN PAN**  
**INSULATED CABINET WITH NO EXPOSED FIBERGLASS INSULATION**



**5-YEAR LIMITED WARRANTY AGAINST COIL LEAKAGE AND DRAN PAN FAILURE.**  
**1-YEAR FUNCTIONAL PARTS WARRANTY.**

**3/4" MPT DRAIN CONNECTIONS**

**3/8" LIQUID LINE**

**SUCTION LINE CONNECTIONS**  
**3/4" ON 1.5 TO 3.0 TONS**  
**7/8" ON 3.5 TO 5.0 TONS**

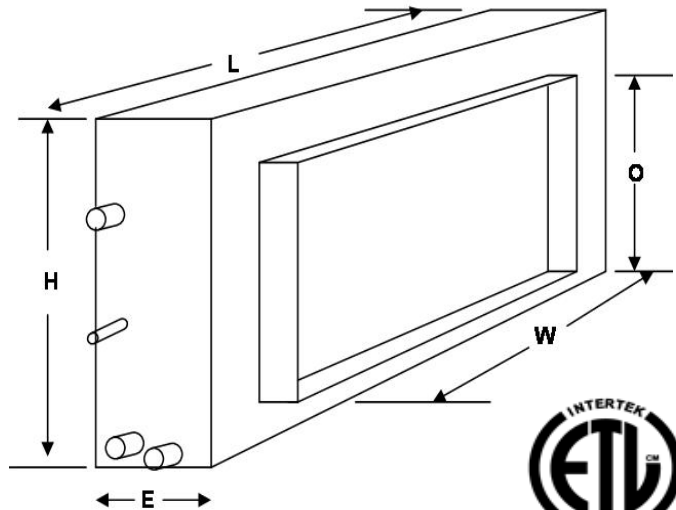

### CABINET DIMENSIONS

Coil Model	Nominal Tonnage	Cabinet Depth L	Cabinet Height H	Cabinet Width E	Inlet/Outlet Width W	Inlet/Outlet Height O
ATCH-024	2.0	25.75	25.5	10	19.75	22
ATCH-036	3.0	25.75	25.5	10	22.25	22
ATCH-048	4.0	32	25.5	10	22.25	22
ATCH-060	5.0	32	25.5	10	22.25	22

Specifications may change without notice.