



# ASLBH SERIES ASPEN REPLACEMENT COIL

## STANDARD FEATURES

**BI-DIRECTIONAL AIR FLOW**  
**EMBOSSED GALVANIZED STEEL CASE**  
**HEAVY RIFLED COPPER TUBING**  
**ALUMINUM FIN**  
**ALUMINUM END PLATES**  
**PRESSURE TESTED TO 450 LBS.**  
**DUAL RATED FOR R-22 AND R-410a**  
**STANDARD POLYMER DRAIN PAN**  
**INSULATED CABINET WITH NO**  
**EXPOSED FIBERGLASS INSULATION**



**5-YEAR LIMITED WARRANTY**  
**AGAINST COIL LEAKAGE AND**  
**DRAN PAN FAILURE.**  
**1-YEAR FUNCTIONAL PARTS**  
**WARRANTY.**

**3/4" MPT DRAIN**  
**CONNECTIONS**

**3/8" LIQUID LINE**

**SUCTION LINE CONNECTIONS**  
**3/4" ON 1.5 TO 3.0 TONS**  
**7/8" ON 3.5 TO 5.0 TONS**

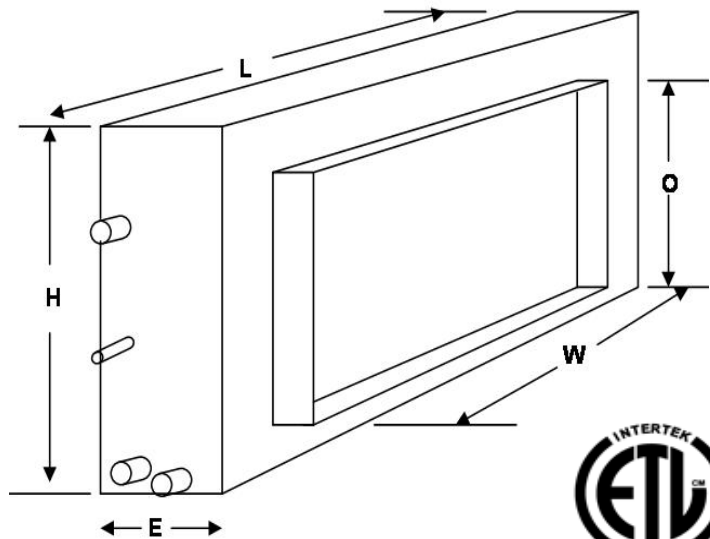

## CABINET DIMENSIONS

Coil Model	Nominal Tonnage	Cabinet Number	Dim'n L	Dim'n H	Dim'n W	Dim'n O	Dim'n E
ASLBH-24	2.0	#1	27"	18"	21.5"	14.5"	10"
ASLBH-36	3.0	#1	27"	18"	21.5"	14.5"	10"
ASLBH-48	4.0	#2	36"	18"	29"	14.5"	10"
ASLBH-60	5.0	#3	36"	22"	29"	18.5"	10"

Specifications may change without notice.