

AllStyle

ASHL SERIES REPLACEMENT COIL

STANDARD FEATURES



REPLACES RED-T LOW PROFILE
 HORIZONTAL COILS
 EMBOSSED GALVANIZED STEEL CASE
 HEAVY RIFLED COPPER TUBING
 ALUMINUM FINS
 ALUMINUM END PLATES TO REDUCE CORROSION
 PRESSURE TESTED TO 450 LBS.
 DUAL RATED FOR R-22 AND R-410a
 STANDARD POLYMER DRAIN PAN
 INSULATED CABINET WITH NO
 EXPOSED FIBERGLASS INSULATION

**5-YEAR LIMITED WARRANTY
 AGAINST COIL LEAKAGE AND
 DRAN PAN FAILURE.**

**1-YEAR FUNCTIONAL PARTS
 WARRANTY.**

**3/4" MPT DRAIN
 CONNECTIONS**

3/8" LIQUID LINE

SUCTION LINE CONNECTIONS

**3/4" ON 1.5 TO 3.0 TONS
 7/8" ON 3.5 TO 5.0 TONS**

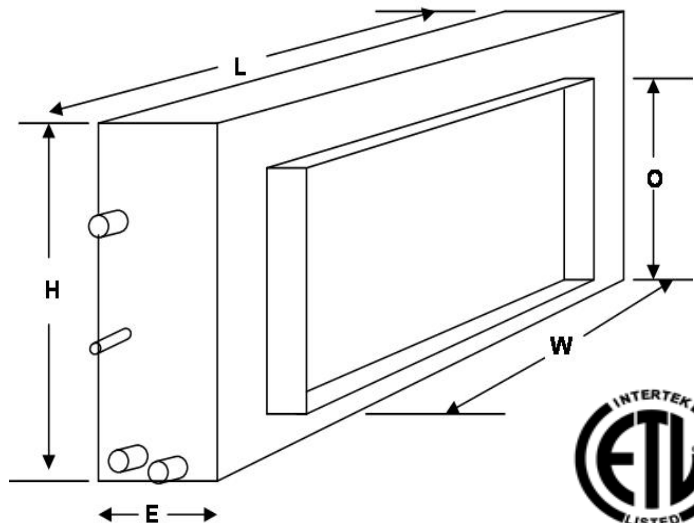

Inlet & outlet plenum dimensions are the same.

CABINET DIMENSIONS						
Coil Model	Nominal Tonnage	Length L	Depth E	Height H	Duct W	Dimension O
ASHL24-2622T	2.0	30.00"	10.00"	20.50"	20.00-22.00"	17.00"
ASHL36-2632T	3.0	30.00"	10.00"	20.50"	20.00-22.00"	17.00"
ASHL48-3032T	4.0	32.50"	10.00"	20.50"	20.00-22.00"	17.00"
ASHL60-3040T	5.0	32.50"	10.00"	20.50"	28.00"	17.00"

Specifications may change without notice