



# ASH SERIES HORIZONTAL COIL

## STANDARD FEATURES

- EMBOSSED GALVANIZED STEEL CASE
- HEAVY RIFLED COPPER TUBING
- ALUMINUM FINNS
- HEAVY ALUMINUM END PLATES  
TO REDUCE CORROSION
- PRESSURE TESTED TO 450 LBS.
- DUAL RATED FOR R-22 AND R-410a
- STANDARD POLYMER DRAIN PAN
- INSULATED CABINET WITH NO  
EXPOSED FIBERGLASS INSULATION



**5-YEAR LIMITED WARRANTY  
AGAINST COIL LEAKAGE AND  
DRAN PAN FAILURE. 1-YEAR  
FUNCTIONAL PARTS  
WARRANTY.**

**3/4" MPT DRAIN CONNEC-  
TIONS  
3/8" LIQUID LINE**

**SUCTION LINE CONNECTIONS  
3/4" ON 1.5 TO 3.0 TONS  
7/8" ON 3.5 TO 5.0 TONS**

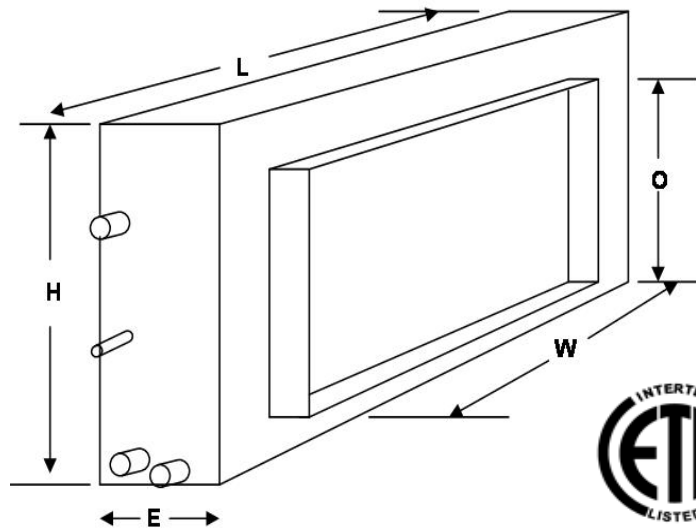

Inlet and outlet plenum connections are the same dimen-

### CABINET DIMENSIONS

Cabinet Model Number	Coil Selection	Cabinet Length L	Cabinet Width E	Cabinet Height H	Plenum Length W	Plenum Height O
5	LSC, M4C, O2C	22.00"	10.00"	24.50"	16.00"	21.00"
5B	L4C, O4C	24.30"	10.00"	24.50"	16.00"	21.00"
6	Q4C, S4C, 2Q6T, Q2C, Q2TC	30.00"	10.00"	24.50"	24.00"	21.00"
6B	T4C	32.00"	10.00"	24.50"	24.00"	21.00"
7	A4C, AOC	36.00"	10.00"	24.50"	30.00"	21.00"
7B	AZO	37.00"	10.00"	24.50"	34.00"	21.00"